

Ultra-small Diaphragm-isolation Latching Solenoid Valve FLV Series

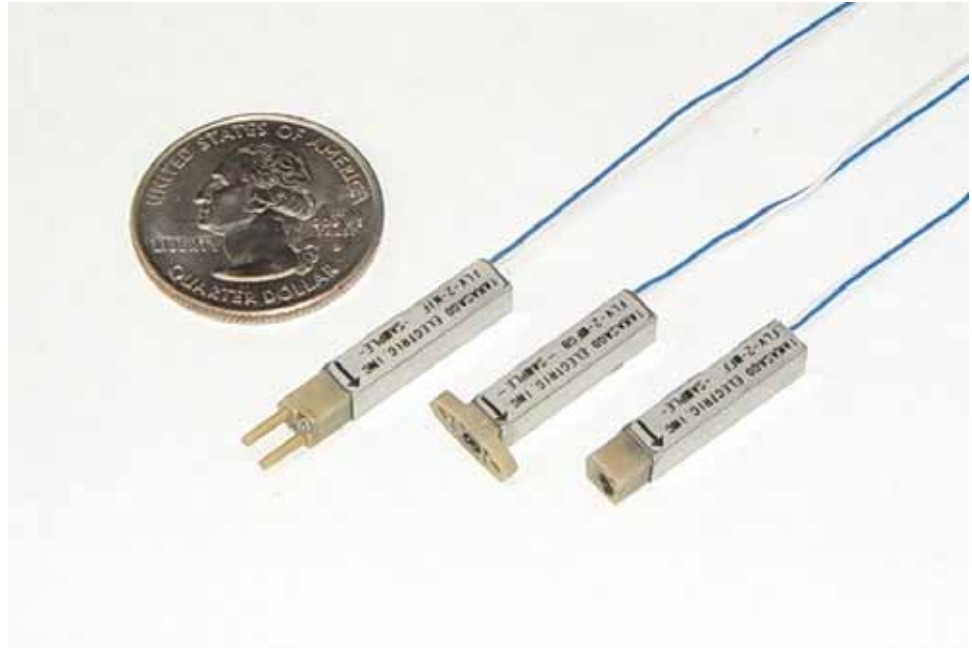

1. 4.2mm square: 4.2 × 4.2 × 23.1mm*¹

An innovative and groundbreaking ultra-small solenoid valve - can be mounted in the smallest of spaces, minimizing the manifold size and shortening the length of flow paths.

*1 Dimensions for FLV-2-MFG, not including wire connections

2. Diaphragm valve

Excellent chemical resistance – PEEK and Perfluorelastomer are used for wetted materials (materials can be changed according to your requirements).

3. Internal volume only 1.1μl*²

Through pursuing miniaturization to the uttermost limits, internal volume is now only 1.1μl – contributes to reductions in reagent and sample quantities and improvements in analysis accuracy.

*2: value for FLV-2-MFGA(B). FLV-2-N1G: 4.3 μl, FLV-2-MFG: 1.5 μl

4. Latching Solenoid Valve

The open status of valve is maintained by magnetic force. No energization is required to maintain the valve status. Contributes to energy saving and lower heat generation through energization. See page 3.

TAKASAGO ELECTRIC, INC.

66 KAKITSUBATA, NARUMI-CHO, MIDORI-KU, NAGOYA, 458-8522 JAPAN

Tel +81-52-891-2301 Fax+81-52-891-7386

E-mail: info@takasago-elec.co.jp URL: <http://www.takasago-elec.co.jp/>

Specifications

Model number	FLV-2-N1G	FLV-2-MFGA(B) ^{*1}	FLV-2-MFG
Type	2 Way		
Orifice Diameter	0.4mm		
Port Connection	Hose Barb	Gasket	
Coil Type	Latch Type Solenoid		
Operating Pressure Range	IN:0 – 100kPa		
	OUT:0 – 50kPa		
Fluid Temp. Range	10 - 50°C		
Ambient Temp. Range	10 - 50°C		
Voltage	12VDC, 24VDC		
Power Consumption	2.4W (When energized)		
Diaphragm Material	Perfluorelastomer (Optionally FPM)		
Body Material	PEEK		
Hose Barb Material	PEEK	-	

*1 A and B have a 90° difference in port orientation.

Dimensions

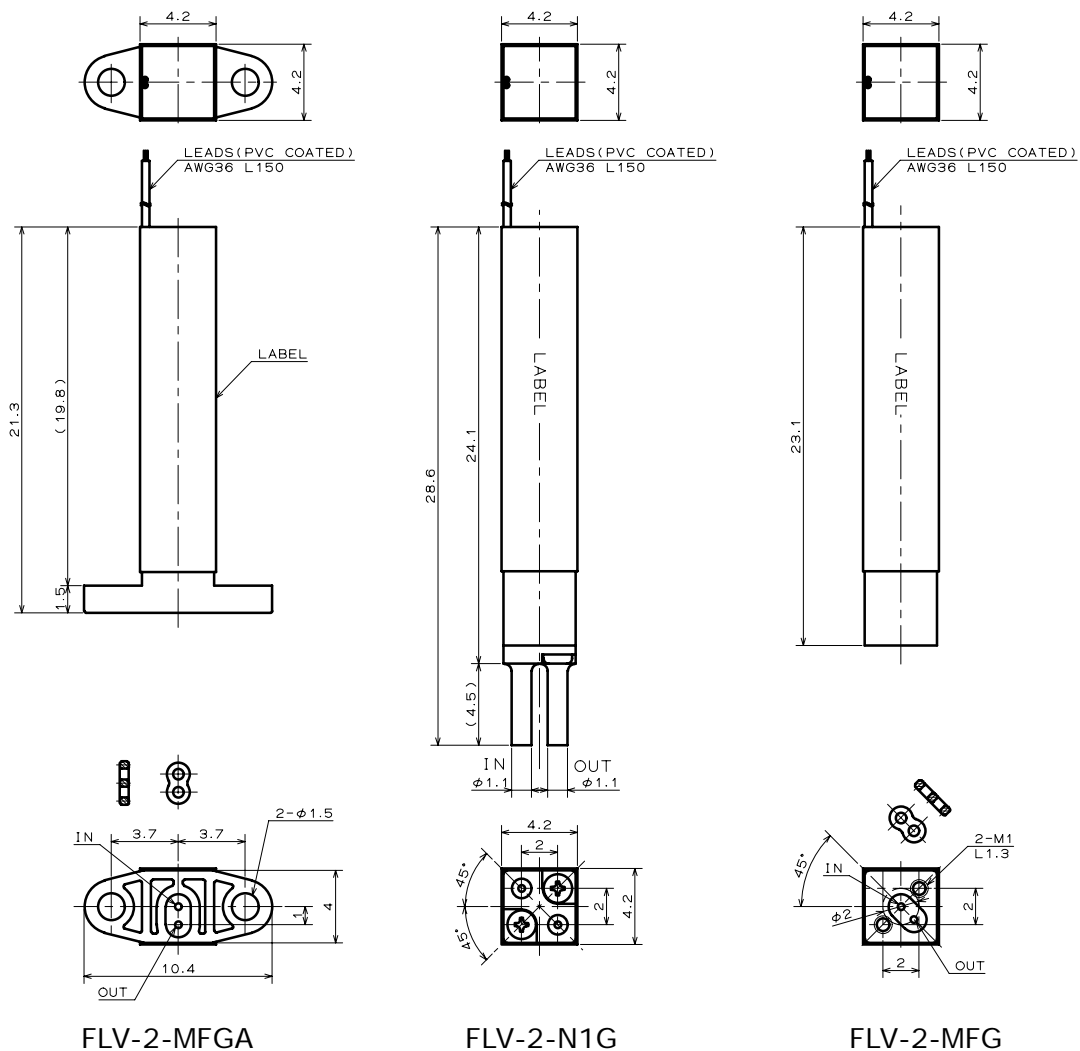

FLV-2-MFGA

FLV-2-N1G

FLV-2-MFG

Latching Solenoid Valve

In the case of a normally closed type of conventional solenoid valve, continuous energization is required to maintain open status. The latching solenoid doesn't require a power supply for the purpose of maintaining open status through the utilization of a permanent magnet.

Merits of the Latching Solenoid Valve

1. Energy saving

Valve does not require energizing to maintain its state, so for applications where a conventional valve would require long periods of energization the economical benefits are significant.

Note: Power is required during changing of state (Open to Closed, Closed to Open). Also, it is necessary to reverse the polarity of the current to change the state.

2. Low heat generation, decreased thermal influence on surroundings

As energization is not required to maintain state, the heat generation associated with energization is reduced. Suitable for analytical fields and other applications where the effect of temperature on a fluid is a concern.